

# FR 785 SCC



<b>SLIDE TYPE:</b>	Progressive-Action Full-Extension Drawer Slide
<b>MOUNTING:</b>	Side Mount

<b>WIDTH:</b>	18 mm
<b>LOAD CAPACITY:</b>	dynamic up to <b>60 kg</b> (full-ext.) dynamic up to <b>48 kg</b> (over-ext.)

	ORDER OPTIONALLY
	<b>SM-021 Easy Close Device</b>
	Order No.: ▶ <b>82503</b>
	Packing Unit: <b>1 set per polybag</b>



<b>MATERIAL:</b>	stainless steel 1.4509 (SCC)
------------------	------------------------------

<b>FEATURES:</b>	solid delrin* rollers
------------------	-----------------------

- SPECIFICATIONS & NOTES:**
- ▶ cabinet and drawer profile with screw holes
  - ▶ high lateral stability through specially formed middle profile (material thickness 2 mm) and guide rollers
  - ▶ ideal running characteristic and smoothness of running through integrated progressive-action
  - ▶ safety clip mounted in middle profile
  - ▶ double-sided captive profile
  - ▶ self closing, soft stop
- ① compatible with regular-extension drawer slide FR 1052 CS
- ② also available with 60 mm over-extension
- ③ also available with **Easy Close Device (ECD)**
- ④ on request, also available as heat resistant model (up to 110° C) – load capacity 45 kg (full-ext.), 35 kg (over-ext.)

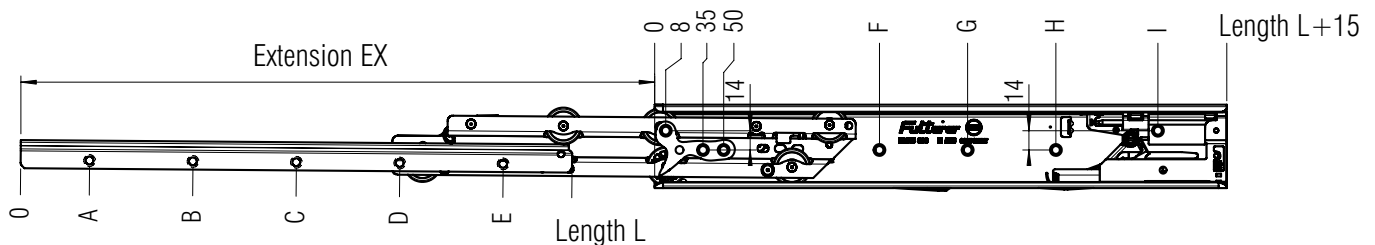
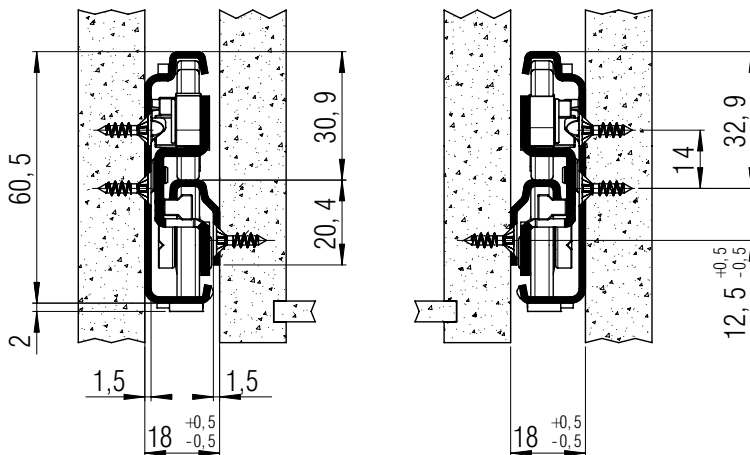

screw holes for 3,5 mm spax screws

L mm	EX full-ext.	EX over-ext.	A mm	B mm	C mm	D mm	E mm	F mm	G mm	H mm	I mm	Weight per pair (kg)	Order No. full-ext.	Order No. over-ext.
335	320	395	28	156	316			163			315	*	*	*
350	335	410	28	156	316			163			315	*	▶ 8522	*
385	370	445	28	156	348			163			350	*	*	*
400	385	460	28	156	380			163			365	*	▶ 8524	*
435	420	495	28	156	316	412		163	323		400	*	*	*
450	435	510	28	156	316	412		163	355		415	*	▶ 8526	*
485	470	545	28	156	348	444		163	355		450	*	*	*
500	485	560	28	156	348	476		163	355		465	*	▶ 8528	*
535	520	595	28	156	348	508		163	355		500	*	*	*
550	535	610	28	156	348	508		163	355		515	*	▶ 8530	*
585	570	645	28	156	348	540		195	355		550	*	*	*
600	585	660	28	156	348	572		195	355		565	*	▶ 8532	*
635	620	695	28	156	348	604		163	355	547	600	*	*	*
650	635	710	28	156	348	604		163	355	547	615	*	▶ 8534	*
685	670	745	28	156	348	540	668	163	355	547	650	*	*	*
700	685	760	28	156	348	540	668	163	355	547	665	*	▶ 8536	*
735	720	795	28	156	348	572	700	163	355	547	700	*	*	*
750	735	810	28	156	348	572	732	163	355	547	715	*	*	*

Packing Unit: **5 sets per box** ▶ prompt delivery \* on request

