

# FR 2051 SCC

<b>SLIDE TYPE:</b>	Regular-Extension Drawer slide
<b>MOUNTING:</b>	Bottom Mount

<b>WIDTH:</b>	15 mm
<b>LOAD CAPACITY:</b>	dyn. up to <b>40 kg</b> (steel ball bearings) dyn. up to <b>50 kg</b> (silent rollers)



**MATERIAL:** stainless steel 1.4509 (SCC)

**FEATURES:** delrin\*-encased chrome steel ball bearings or silent rollers

- SPECIFICATIONS:**
- ▶ cabinet and drawer profile with screw holes
  - ▶ lateral stability provided by specially shaped profiles
  - ▶ single-sided captive profile (right)
  - ▶ rear backstop
  - ▶ self closing
- 
- ① compatible with full-extension drawer slide FR 6010 SCC
  - ① on request, also available in a heat resistant version for -40 to +210 °C

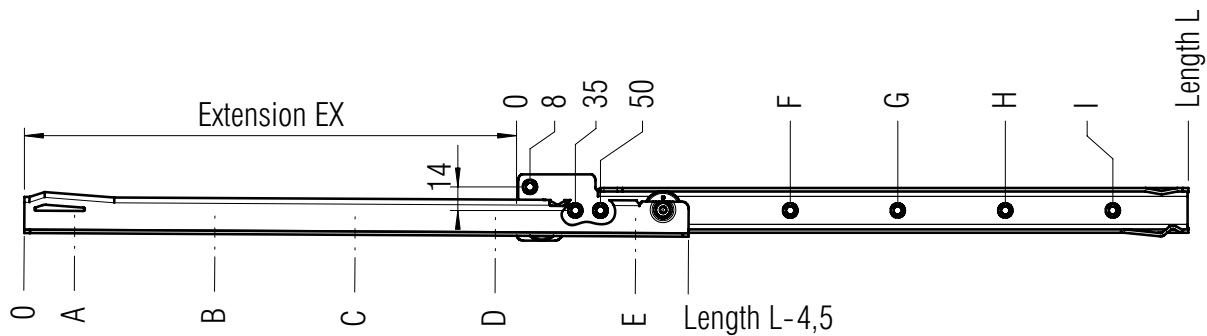
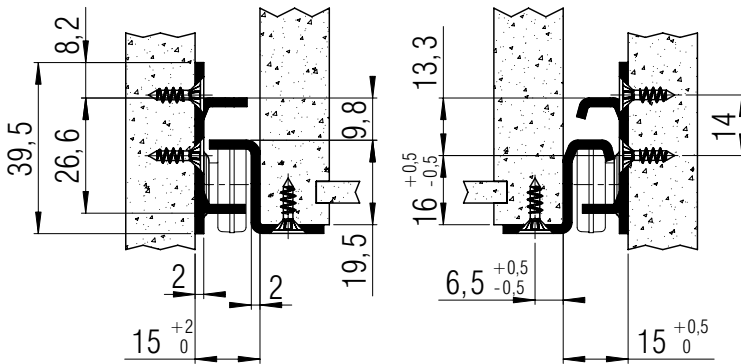

screw holes for 3,5 mm spax screws

L mm	EX mm	A mm	B mm	C mm	D mm	E mm	F mm	G mm	H mm	I mm	Weight per pair (kg)	Order No. steel ball bearings	Order No. silent rollers
400	294	28	156	348			163	355			1,13	▶ 1086	▶ 1510
450	344	28	156	348			163	355			1,27	▶ 1087	▶ 1511
500	394	28	156	348	444		163	355	451		1,41	▶ 1088	▶ 1512
550	424	28	156	348	476		163	355	483		1,54	▶ 1089	▶ 1513
600	474	28	156	348	540		195	355	547		1,68	▶ 1090	▶ 1514
650	524	28	156	348	540		163	355	547		1,82	▶ 1091	▶ 1515
700	574	28	156	380	540	664	163	355	547	643	1,95	▶ 1092	▶ 1516
750	624	28	156	348	572	714	163	355	547	643	2,09	▶ 1093	▶ 1517

Packing Unit: 10 sets per box

▶ prompt delivery

**SLIDING**  
SYSTEMS

**Fulterer**

Unit 9, Gledrid Industrial Park, Chirk, Wrexham, UK, LL14 5DG / Tel: +44 (0)1691 770303 / Fax: +44 (0)1691 776900 / Email: info@gsfslides.com