

SDTS-40 weighs 5.75 kg/m. Sold as singles				Drilling pattern		
Part number	Closed Length:L	Extension Length:D	Load per Pair: kg	"A"	"B"	"C"
4015.SDTS040.0200	200	200	189	50	-	-
4015.SDTS040.0250	250	250	196	50	-	50
4015.SDTS040.0300	300	300	203	50	-	100
4015.SDTS040.0350	350	350	210	50	-	150
4015.SDTS040.0400	400	400	217	50	-	200
4015.SDTS040.0450	450	450	224	50	-	250
4015.SDTS040.0500	500	500	231	50	-	300
4015.SDTS040.0550	550	550	245	50	150	-
4015.SDTS040.0600	600	600	238	50	175	-
4015.SDTS040.0650	650	650	224	50	200	-
4015.SDTS040.0700	700	700	210	50	225	-
4015.SDTS040.0750	750	750	203	50	250	-
4015.SDTS040.0800	800	800	196	50	275	-
4015.SDTS040.0850	850	850	189	50	300	-
4015.SDTS040.0900	900	900	175	50	325	-
4015.SDTS040.0950	950	950	161	50	350	-
4015.SDTS040.1000	1000	1000	154	50	375	-
4015.SDTS040.1050	1050	1050	147	50	400	-
4015.SDTS040.1100	1100	1100	140	50	425	-
4015.SDTS040.1150	1150	1150	133	50	450	-
4015.SDTS040.1200	1200	1200	126	50	475	-
4015.SDTS040.1250	1250	1250	119	50	500	-
4015.SDTS040.1300	1300	1300	112	50	525	-
4015.SDTS040.1350	1350	1350	108	50	550	-
4015.SDTS040.1400	1400	1400	105	50	575	-
4015.SDTS040.1450	1450	1450	101	50	600	-
4015.SDTS040.1500	1500	1500	98	50	625	-
4015.SDTS040.1550	1550	1550	91	50	650	-
4015.SDTS040.1600	1600	1600	84	50	675	-
4015.SDTS040.1650	1650	1650	77	50	700	-
4015.SDTS040.1700	1700	1700	70	100	650	-
4015.SDTS040.1750	1750	1750	63	100	675	-
4015.SDTS040.1800	1800	1800	56	100	700	-



Professional Range - **Stainless Steel**

Full Extension Telescopic Slide

Type: **SDTS-40**

Version: 2023/1

SDTS-40

SLIDING
SYSTEMS

Options:

- 'F' - One mounting beam countersunk
- 'FF' - Both beams countersunk
- 'V' - V shaped raceways (bi-directional slides)
- '120' - 120% over-extension of standard slide

Bespoke length, drilling pattern & extension on request

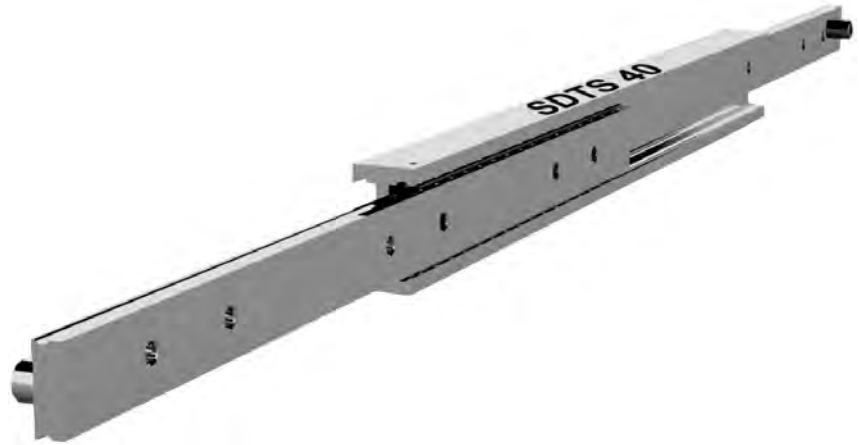

Do not dismantle the slide! 

The maximum safe working load is stated for a fully extended pair of slides, mounted upright. Use all fixing holes and spread the load evenly across the inner beam.

Flat mounting: Reduce the load by 60-80%.

We recommend the use of strong L brackets for under or floor mount.

Deflection is calculated at approx 1% of the closed length, at or near full load capacity.



If mounting on the indirect axis, flat, as in the image above, reduce the load capacity by 60-80% and allow for increased deflection, or contact our engineers to request accurate FEA load analysis for OEM projects. We load rate per fully extended pair of slides on the direct axis, upright, with uniform loading across the beams. If load capacities need to be increased, please contact us for technical advice.

Material: All austenitic stainless steel parts

Beams: Stainless 316L (1.4404) precision milled

Ball bearings: Stainless 316L (1.4404)

Ball cages: Stainless 316L (1.4404)

End bolts & stopping pins: Stainless A2 304 (1.4301)

Surface treatment: Polished

Temperature range: Cryogenic to $\approx 800^{\circ}$ C with suitable lubrication & material yield strength reduction

Lubrication: We apply and recommend lithium based EP3 grease for general applications. High & low temp grease upon request

Thread pitches: As per end profile image - coarse



'Global Company, Global Reach'