

R22 Rail & Carrier

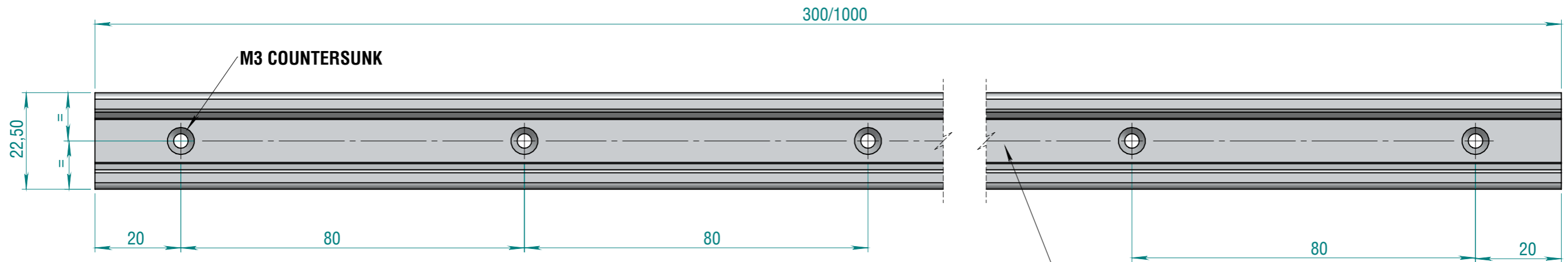

**CARRIER CAN WORK
IN HORIZONTAL AND
VERTICAL POSITION
(MAX LOAD 5 KG)**

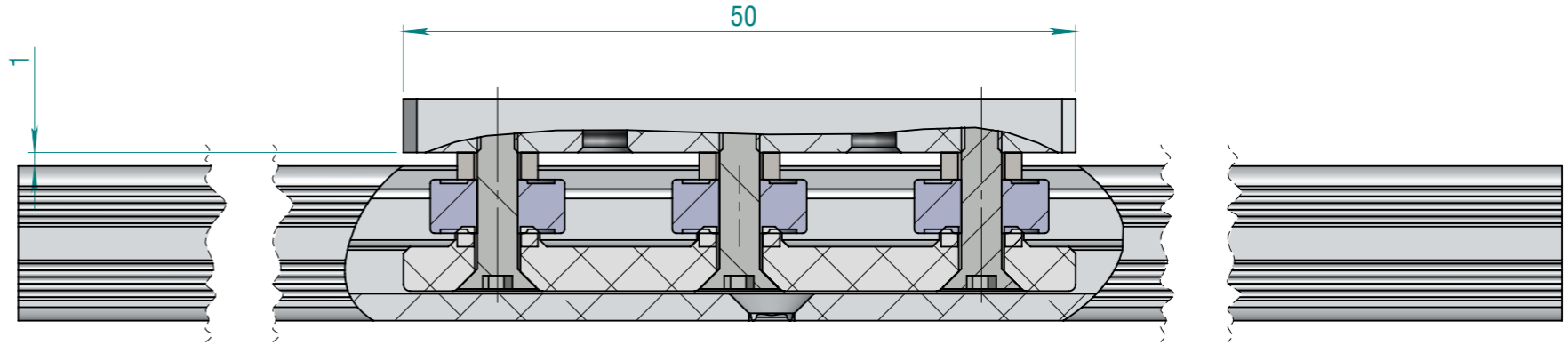
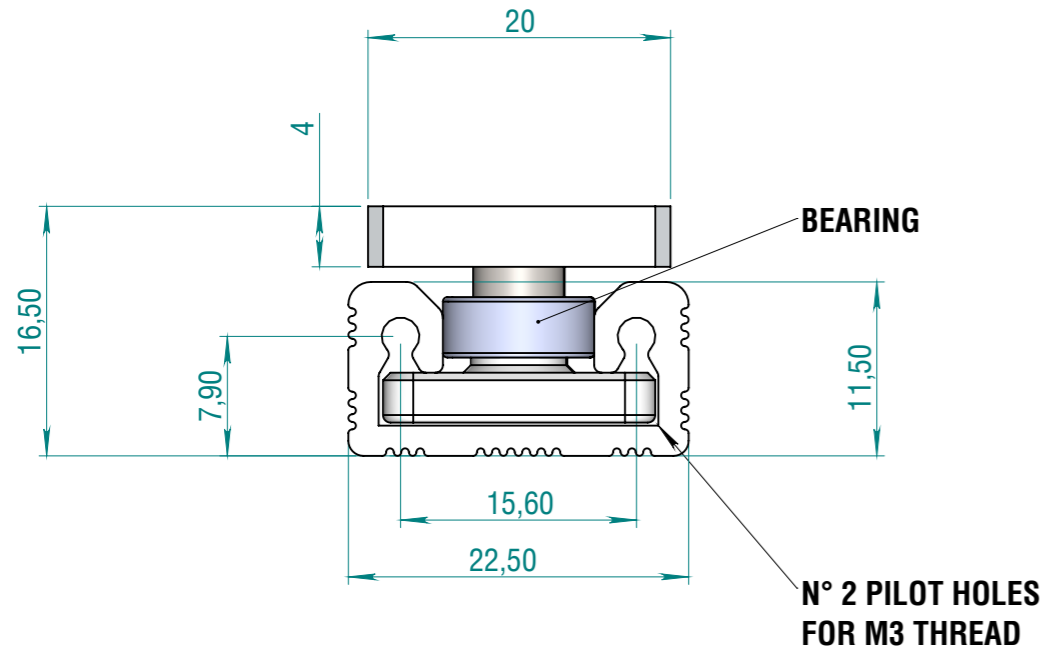

**ALUMINIUM PROFILE
FROM 300 TO 1000
CAN BE SUPPLIED ALREADY DRILLED
(UPON REQUEST)
FOR PROFILE LONGER THAN 1000
(MAX LENGTH 5500 mm)
SUPPLIED ONLY WITHOUT HOLES**

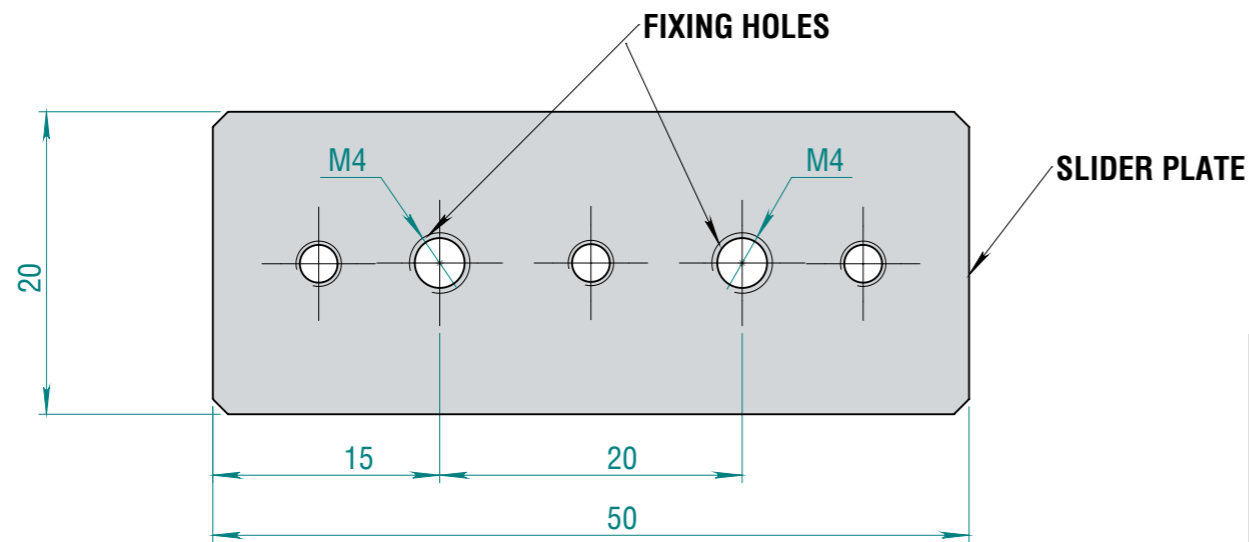

Denominazione GUIDA CURSORE CEL		Tolleranze e scostamento (compreso di protezione superficiale) UNI-ISO 2768/1		Disegno -
Cliente / Rif. progetto R22 Rail & Carrier		Materiale /	Peso 307.96 g	Trattamento /
Progettista Bruno	Quantità	Scala 1:2	Foglio 1:1	Revisione
				Data 12/09/2017

Il presente disegno è di proprietà riservata con divieto di riprodurlo o modificarlo senza autorizzazione di radia