

M10 threaded holes on both inner beams for bolting into

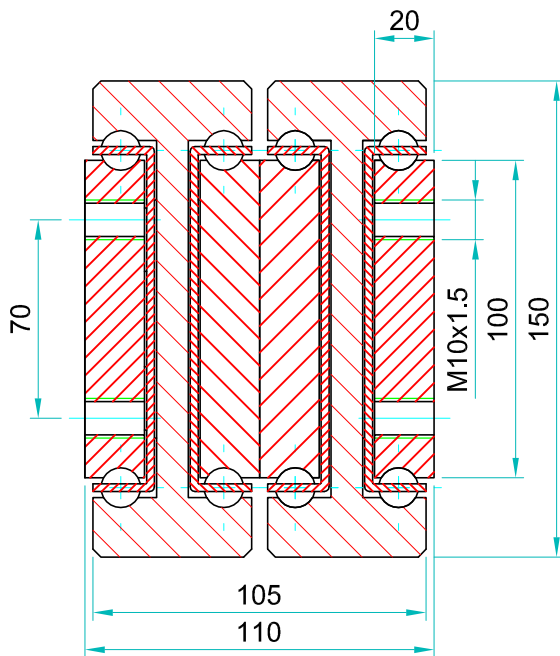

DDTS-150 weighs 110.52 kg/m. Sold as singles				Drilling pattern		
Part Number	Closed Length: L	Extension Length: D	Load per pair: kg	"A"	"B"	"C"
4015.DDTS150.0300	300	600	1120	100	-	-
4015.DDTS150.0350	350	700	1170	50	-	50
4015.DDTS150.0400	400	800	1220	50	-	100
4015.DDTS150.0450	450	900	1280	50	-	150
4015.DDTS150.0500	500	1000	1330	50	-	200
4015.DDTS150.0550	550	1100	1380	50	-	250
4015.DDTS150.0600	600	1200	1440	50	-	300
4015.DDTS150.0650	650	1300	1460	50	150	-
4015.DDTS150.0700	700	1400	1490	50	175	-
4015.DDTS150.0750	750	1500	1510	50	200	-
4015.DDTS150.0800	800	1600	1540	100	150	-
4015.DDTS150.0850	850	1700	1520	100	175	-
4015.DDTS150.0900	900	1800	1500	100	200	-
4015.DDTS150.0950	950	1900	1480	100	225	-
4015.DDTS150.1000	1000	2000	1460	100	250	-
4015.DDTS150.1050	1050	2100	1440	100	275	-
4015.DDTS150.1100	1100	2200	1410	100	300	-
4015.DDTS150.1150	1150	2300	1390	100	325	-
4015.DDTS150.1200	1200	2400	1350	100	350	-
4015.DDTS150.1250	1250	2500	1330	100	375	-
4015.DDTS150.1300	1300	2600	1300	100	400	-
4015.DDTS150.1350	1350	2700	1275	100	425	-
4015.DDTS150.1400	1400	2800	1250	100	450	-
4015.DDTS150.1450	1450	2900	1225	100	475	-
4015.DDTS150.1500	1500	3000	1200	100	500	-
4015.DDTS150.1550	1550	3100	1180	100	525	-
4015.DDTS150.1600	1600	3200	1160	100	550	-
4015.DDTS150.1650	1650	3300	1130	100	575	-
4015.DDTS150.1700	1700	3400	1100	100	600	-
4015.DDTS150.1750	1750	3500	1060	100	625	-
4015.DDTS150.1800	1800	3600	1000	100	650	-
4015.DDTS150.1850	1850	3700	940	100	675	-
4015.DDTS150.1900	1900	3800	880	100	700	-
4015.DDTS150.1950	1950	3900	820	100	725	-
4015.DDTS150.2000	2000	4000	760	100	750	-
4015.DDTS150.2050	2050	4100	700	100	775	-
4015.DDTS150.2100	2100	4200	640	100	800	-
4015.DDTS150.2150	2150	4300	580	100	825	-
4015.DDTS150.2200	2200	4400	520	100	850	-
4015.DDTS150.2250	2250	4500	460	100	875	-
4015.DDTS150.2300	2300	4600	400	100	900	-
4015.DDTS150.2350	2350	4700	340	100	925	-
4015.DDTS150.2400	2400	4800	280	100	950	-
4015.DDTS150.2450	2450	4900	220	100	975	-
4015.DDTS150.2500	2500	5000	160	100	1000	-

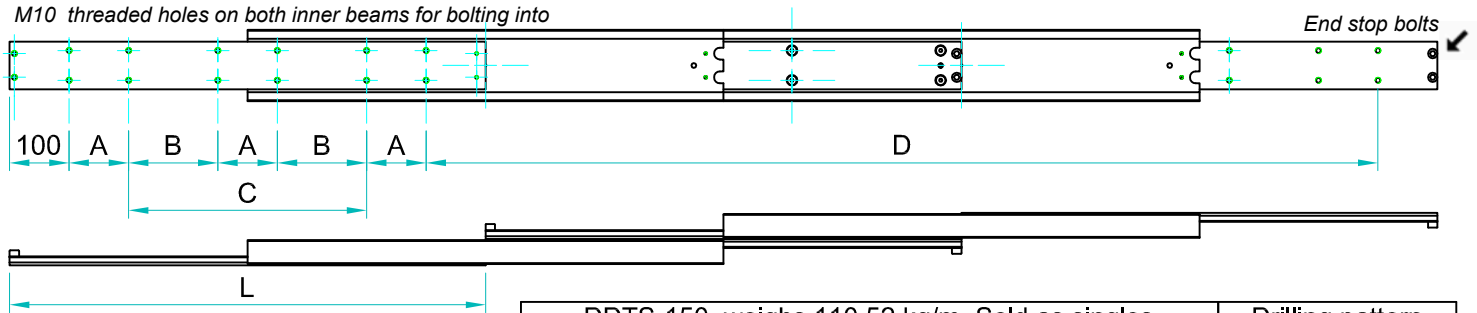

Material: All steel parts/no plastics

Beams: Cold drawn carbon steel C45E+C. EN 10277 milled raceways

Ball bearings: Chromed steel C85, G100. Din 5401

Ball cages: Zinc plated sheet steel. Laser cut profiles

End bolts: Steel ASTM A307

Surface Protection: Electrolytic alkaline zinc coating (10-12 microns). conforming to DIN EN ISO 9227 neutral salt spray testing. No white rust appearance within 120 hours. No red rust within 1,032 hours

Temperature range: Steel slides -20°C to $+250^{\circ}\text{C}$ provided the necessary lubricants are applied and the beams are mounted freely to allow expansion

Lubrication: We apply and recommend lithium based EP3 grease for general applications. High & low temp grease upon request

Thread pitches: As per end profile image - coarse

Options:

'F' - One mounting beam countersunk

'FF' - Both beams countersunk

'SB' - Stainless steel 316L ball bearings

'SC' - Stainless steel ball cages

'SA' - Stainless end bolts & retaining pins

'V' - V shaped raceways (bi-directional slides)

Bespoke length, drilling pattern & extension on request



Do not dismantle the slide!



The maximum safe working load is stated for a fully extended pair of slides, mounted upright. Use all fixing holes and spread the load evenly across the inner beam.

Flat mounting: Reduce the load by 60-80%.

We recommend the use of strong L brackets for under or floor mount.

Deflection is calculated at approx 1% of the closed length, at or near full load capacity.

If mounting on the indirect axis, flat, as in the image above, reduce the load capacity by 60-80% and allow for increased deflection, or contact our engineers to request accurate FEA load analysis for OEM projects. We load rate per fully extended pair of slides on the direct axis, upright, with uniform loading across the beams. If load capacities need to be increased, please contact us for technical advice.