

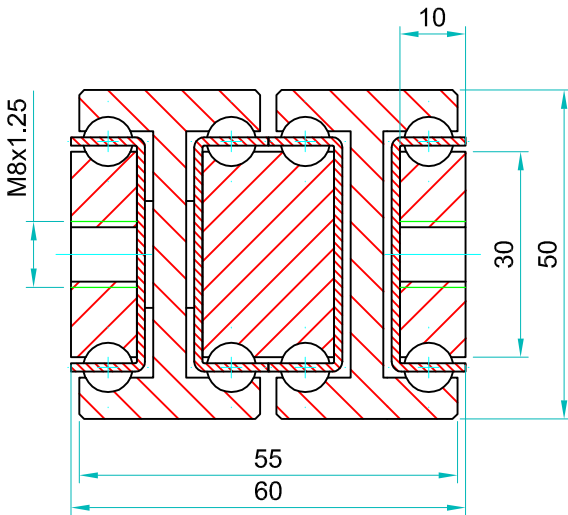

M8 threaded holes on both inner beams for bolting into

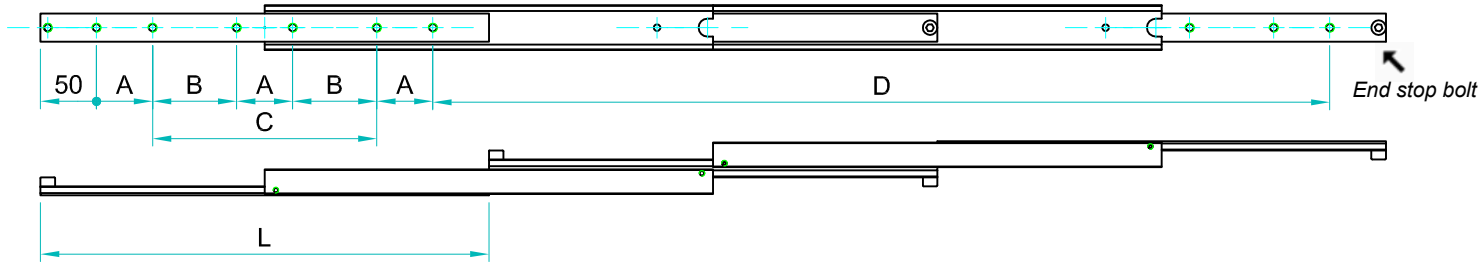

DDTS-50 weighs 17.98 kg/m. Sold as singles

Part Number	Drilling Pattern					
	Closed Length: L	Extension Length: D	Load per Pair: kg	"A"	"B"	"C"
4015.DDTS050.0200	200	400	190	50	-	-
4015.DDTS050.0250	250	500	195	50	-	50
4015.DDTS050.0300	300	600	200	50	-	100
4015.DDTS050.0350	350	700	210	50	-	150
4015.DDTS050.0400	400	800	220	50	-	200
4015.DDTS050.0450	450	900	225	50	-	250
4015.DDTS050.0500	500	1000	230	50	-	300
4015.DDTS050.0550	550	1100	235	50	150	-
4015.DDTS050.0600	600	1200	240	50	175	-
4015.DDTS050.0650	650	1300	232	50	200	-
4015.DDTS050.0700	700	1400	225	50	225	-
4015.DDTS050.0750	750	1500	218	50	250	-
4015.DDTS050.0800	800	1600	210	50	275	-
4015.DDTS050.0850	850	1700	195	50	300	-
4015.DDTS050.0900	900	1800	182	50	325	-
4015.DDTS050.0950	950	1900	172	50	350	-
4015.DDTS050.1000	1000	2000	160	50	375	-
4015.DDTS050.1050	1050	2100	155	50	400	-
4015.DDTS050.1100	1100	2200	150	50	425	-
4015.DDTS050.1150	1150	2300	145	50	450	-
4015.DDTS050.1200	1200	2400	140	50	475	-
4015.DDTS050.1250	1250	2500	135	50	500	-
4015.DDTS050.1300	1300	2600	130	50	525	-
4015.DDTS050.1350	1350	2700	125	50	550	-
4015.DDTS050.1400	1400	2800	120	50	575	-
4015.DDTS050.1450	1450	2900	115	50	600	-
4015.DDTS050.1500	1500	3000	110	50	625	-
4015.DDTS050.1550	1550	3100	105	50	650	-
4015.DDTS050.1600	1600	3200	100	50	675	-



If mounting on the indirect axis, flat, as in the image above, reduce the load capacity by 60-80% and allow for increased deflection, or contact our engineers to request accurate FEA load analysis for OEM projects. We load rate per fully extended pair of slides on the direct axis, upright, with uniform loading across the beams. If load capacities need to be increased, please contact us for technical advice.

Material: All steel parts/no plastics

Beams: Cold drawn carbon steel C45E+C. EN 10277 milled raceways

Ball bearings: Chromed steel C85, G100. Din 5401

Ball cages: Zinc plated sheet steel. Laser cut profiles

End bolts: Steel ASTM A307

Surface Protection: Electrolytic alkaline zinc coating (10-12 microns). conforming to DIN EN ISO 9227 neutral salt spray testing. No white rust appearance within 120 hours. No red rust within 1,032 hours

Temperature range: Steel slides -20°C to $+250^{\circ}\text{C}$ provided the necessary lubricants are applied and the beams are mounted freely to allow expansion

Lubrication: We apply and recommend lithium based EP3 grease for general applications. High & low temp grease upon request

Thread pitches: As per end profile image - coarse

Options:

'F' - One mounting beam countersunk

'FF' - Both beams countersunk

'SB' - Stainless steel 316L ball bearings

'SC' - Stainless steel ball cages

'SA' - Stainless end bolts & retaining pins

'V' - V shaped raceways (bi-directional slides)

Bespoke length, drilling pattern & extension on request

Do not dismantle the slide!



The maximum safe working load is stated for a fully extended pair of slides, mounted upright. Use all fixing holes and spread the load evenly across the inner beam.

Flat mounting: Reduce the load by 60-80%.

We recommend the use of strong L brackets for under or floor mount.

Deflection is calculated at approx 1% of the closed length, at or near full load capacity.