

STR-100 weighs 10.96 kg/m. Sold as singles				Drilling pattern		
Part Number	Closed Length: L	Extension Length: D	Load per pair: kg	"A"	"B"	"C"
4015.STR100.0200	200	200	250	50	-	-
4015.STR100.0250	250	250	280	50	-	50
4015.STR100.0300	300	300	320	50	-	100
4015.STR100.0350	350	350	360	50	-	150
4015.STR100.0400	400	400	390	50	-	200
4015.STR100.0450	450	450	410	50	-	250
4015.STR100.0500	500	500	425	50	-	300
4015.STR100.0550	550	550	435	50	150	-
4015.STR100.0600	600	600	420	50	175	-
4015.STR100.0650	650	650	410	50	200	-
4015.STR100.0700	700	700	400	50	225	-
4015.STR100.0750	750	750	380	50	250	-
4015.STR100.0800	800	800	360	50	275	-
4015.STR100.0850	850	850	340	50	300	-
4015.STR100.0900	900	900	320	50	325	-
4015.STR100.0950	950	950	300	50	350	-
4015.STR100.1000	1000	1000	285	50	375	-
4015.STR100.1050	1050	1050	270	50	400	-
4015.STR100.1100	1100	1100	255	50	425	-
4015.STR100.1150	1150	1150	240	50	450	-
4015.STR100.1200	1200	1200	230	50	475	-
4015.STR100.1250	1250	1250	220	50	500	-
4015.STR100.1300	1300	1300	210	50	525	-
4015.STR100.1350	1350	1350	200	50	550	-
4015.STR100.1400	1400	1400	190	50	575	-
4015.STR100.1450	1450	1450	180	50	600	-
4015.STR100.1500	1500	1500	170	50	625	-
4015.STR100.1550	1550	1550	160	50	650	-
4015.STR100.1600	1600	1600	150	50	675	-
4015.STR100.1650	1650	1650	140	50	700	-
4015.STR100.1700	1700	1700	130	50	725	-
4015.STR100.1750	1750	1750	110	50	750	-
4015.STR100.1800	1800	1800	90	50	775	-
4015.STR100.1850	1850	1850	80	50	800	-
4015.STR100.1900	1900	1900	70	50	825	-
4015.STR100.1950	1950	1950	60	50	850	-
4015.STR100.2000	2000	2000	50	50	875	-

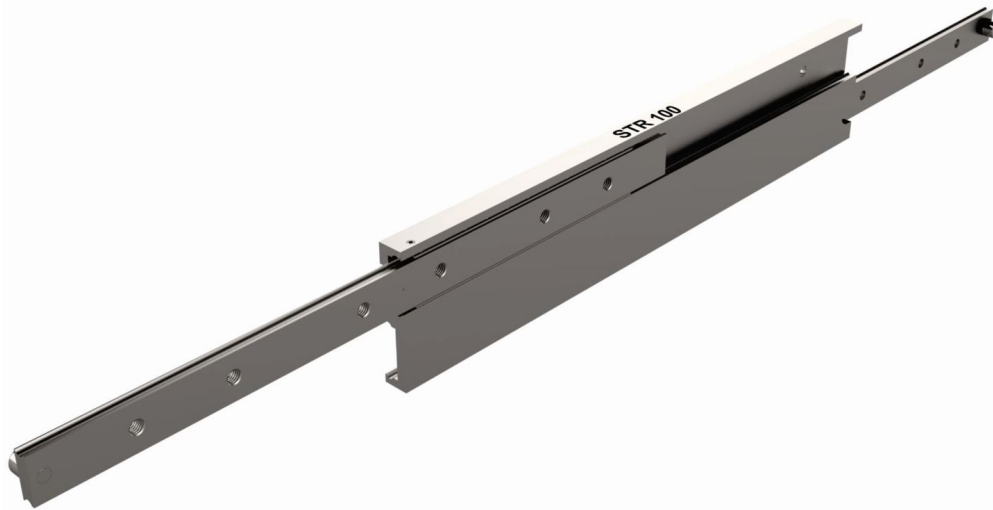

Material: All steel parts/no plastics

Beams: Cold drawn carbon steel C45E+C. EN 10277 milled raceways

Ball bearings: Chromed steel C85, G100. Din 5401

Ball cages: Zinc plated sheet steel. Laser cut profiles

End bolts: Steel ASTM A307

Surface Protection: Electrolytic alkaline zinc coating (10-12 microns). conforming to DIN EN ISO 9227 neutral salt spray testing. No white rust appearance within 120 hours. No red rust within 1,032 hours

Temperature range: Steel slides -20°C to $+250^{\circ}\text{C}$ provided the necessary lubricants are applied and the beams are mounted freely to allow expansion

Lubrication: We apply and recommend lithium based EP3 grease for general applications. High & low temp grease upon request

Thread pitches: As per end profile image - coarse

Options:

'F' - One mounting beam countersunk

'FF' - Both beams countersunk

'SB' - Stainless steel 316L ball bearings

'SC' - Stainless steel ball cages

'SA' - Stainless end bolts & retaining pins

Bespoke length, drilling pattern & extension on request



Do not dismantle the slide!

The maximum safe working load is stated for a fully extended pair of slides, mounted upright. Use all fixing holes and spread the load evenly across the inner beam.

Flat mounting: Reduce the load by 60-80%.

We recommend the use of strong L brackets for under or floor mount.

Deflection is calculated at approx 1% of the closed length, at or near full load capacity.

If mounting on the indirect axis, flat, as in the image above, reduce the load capacity by 60-80% and allow for increased deflection, or contact our engineers to request accurate FEA load analysis for OEM projects. We load rate per fully extended pair of slides on the direct axis, upright, with uniform loading across the beams. If load capacities need to be increased, please contact us for technical advice.